

Sanitary inspections

A sanitary inspection is an on-site inspection of a water supply to identify actual and potential sources of contamination. The physical structure and operation of the system and external environmental factors (such as latrine location) are evaluated. This information can be used to select appropriate remedial action to improve or protect the water supply.

Sanitary inspections should be carried out for all new sources of water before they are used for drinking water, and on a regular basis once the supply is ready for use, or the source is in operation. Inspections should be carried out by a suitably trained person using a simple, clear report form. These forms consist of a set of questions which have “yes” or “no” answers. The questions are structured so that “yes” answers indicate that there is a risk of contamination and “no” answers indicate that the particular risk is absent. Each “yes” answer scores one point and each “no” answer scores zero points. At the end of the inspection the points are added up, and the higher the total the greater the risk of contamination. The report forms are often pictorial to enable them to be easily understood.

The results of sanitary inspections and the remedial actions that need to be taken to improve conditions should be discussed with the community. In small water supplies it is often possible for community members to carry out most of the inspections themselves using a standard form. The information gathered can then be sent to the regional or national surveillance agency, which should also undertake a minimum of one annual inspection to check the reliability of the information.

Some sanitary inspections should be done in conjunction with water quality testing. This is called a sanitary survey. For further information on water quality testing, see Fact Sheets 2.29 to 2.33. Information on water quality testing, sanitary inspections and sanitary surveys can also be found in WHO *Guidelines for drinking water quality*, Volume III (Geneva, 1985).

An example of report forms for a sanitary survey of a dugwell is given below.

SANITARY INSPECTION OF A DUGWELL

General Information	
Location (Town, village, street, etc.):
Water Authority/Local Committee:
Date of Inspection:
Water Sample No: Faecal Coliform Grade:

SANITARY INSPECTION OF A DUGWELL

Code	Specific Information	Risk		Comments
		Yes	No	
1	Is there a latrine within 30 metres of the well?			
2	Is the nearest latrine on higher ground than the well?			
3	Is there any any other source of pollution within 30 metres of the well? (e.g. animal excreta, rubbish, etc)			
4	Is there any ponding of stagnant water within 2 metres of the cement floor of handpump?			
5	Is the handpump drainage channel faulty (e.g. broken, permitting ponding)? Does it need cleaning?			
6	Is there inadequate fencing around the installation, which would allow animals in?			
7	Is the cement floor less than 1 metre radius all around the handpump?			
8	Is there any ponding on the cement floor around the ?			
9	Are there any cracks on the cement floor around the well?			
10	Is a bucket also in use and left in a place where it could be contaminated?			
11	Is the handpump loose at the point of attachment to base (which could permit water to enter the casing)?			
12	Is the cover of the well not properly clean?			
13	Are the walls of the well inadequately sealed at any point for 3 metres below ground level?			

Conclusions

Overall comments on sanitary risks based on the findings of the questionnaire applied during the field visit to the dugwell. Report to be discussed with the local committee/water and sanitation agency. Agreement should be reached on the scheduling of activities to be conducted to minimize the risks of water contamination.

Recommendations

Recommendation	Proposed Implementation Date	Responsible Person/Agency	Approximate Cost

Fact Sheet 2.1

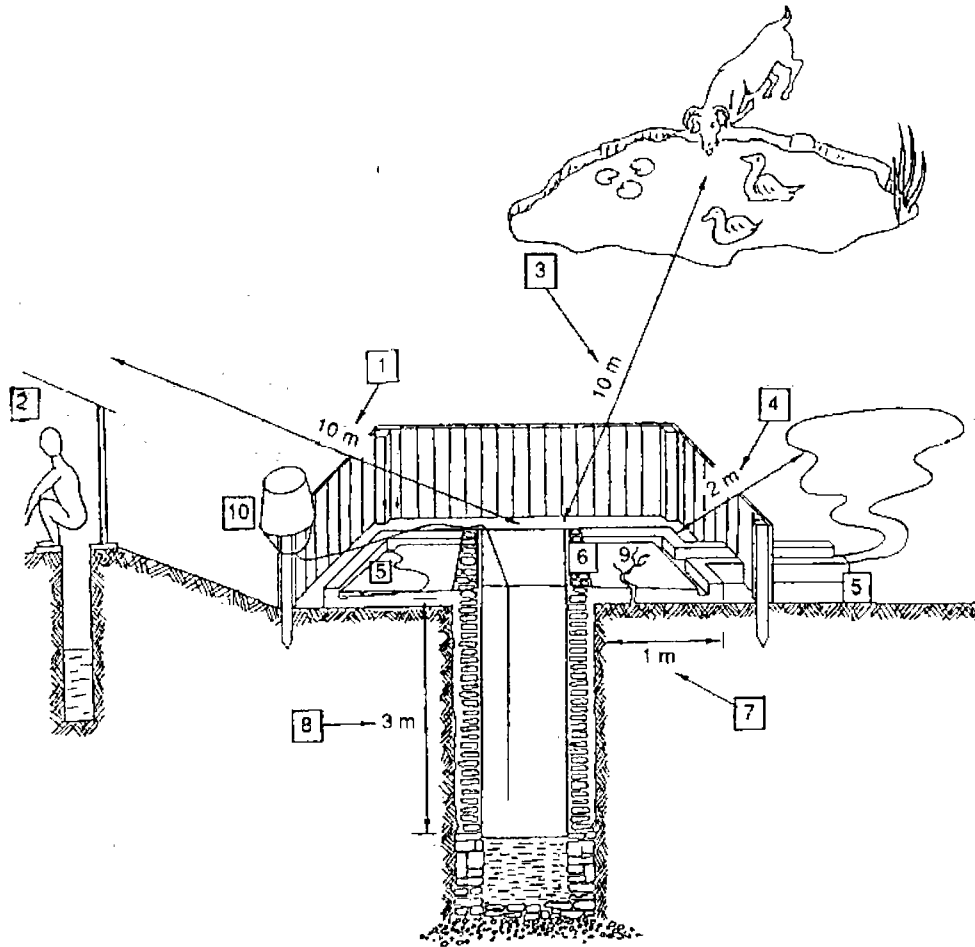

Circle all sanitary risks in red.

Advise pot chlorination where risk score is greater than 3.

Separate sheet along dotted line & give the diagram to the owner of the facility. _____

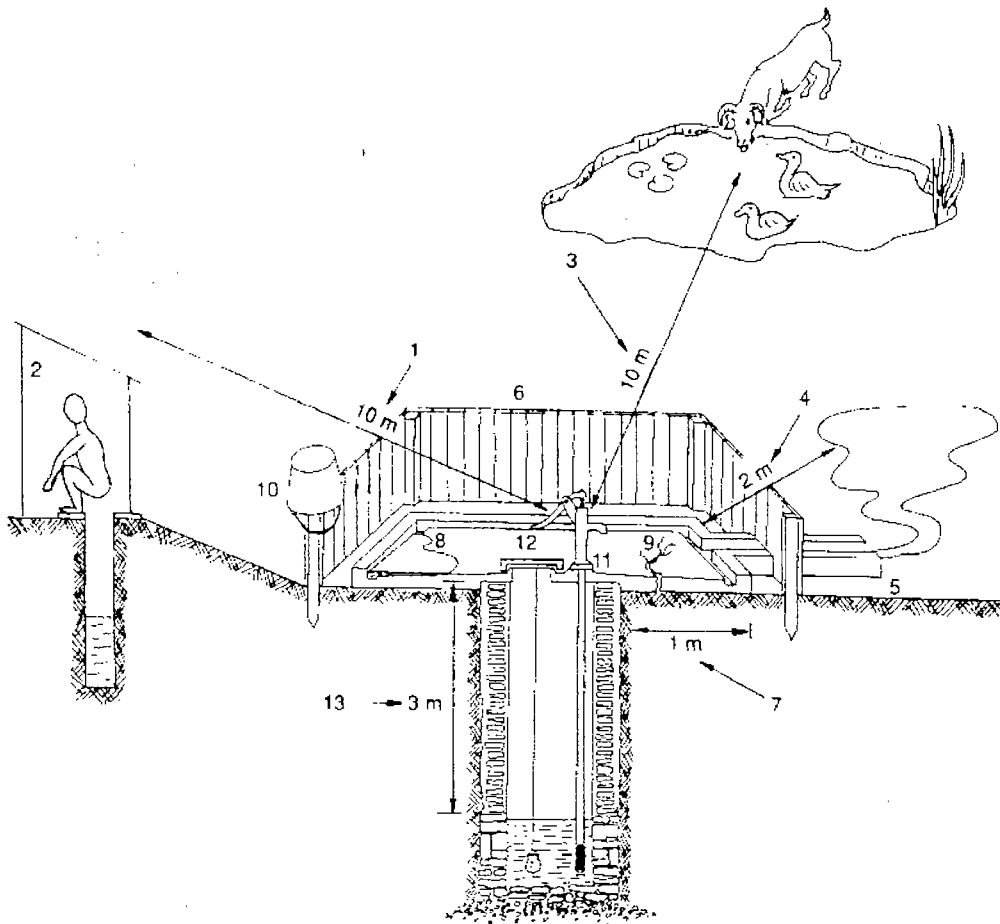

Circle all sanitary risks in red

Advise pot chlorination where risk score is greater than 3.

Separate sheet along dotted line & give the diagram to the owner of the _____
facility or the community representative.

Fact Sheet 2.1

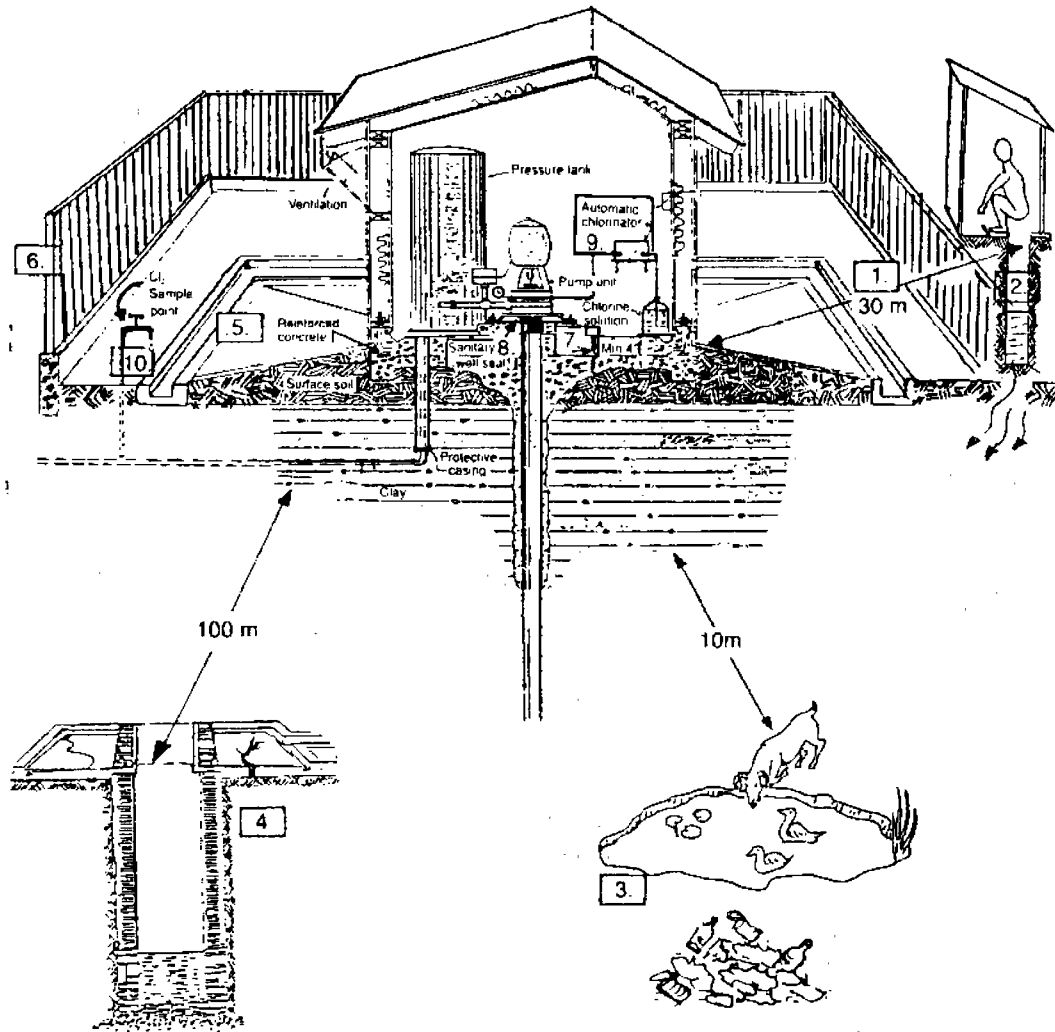

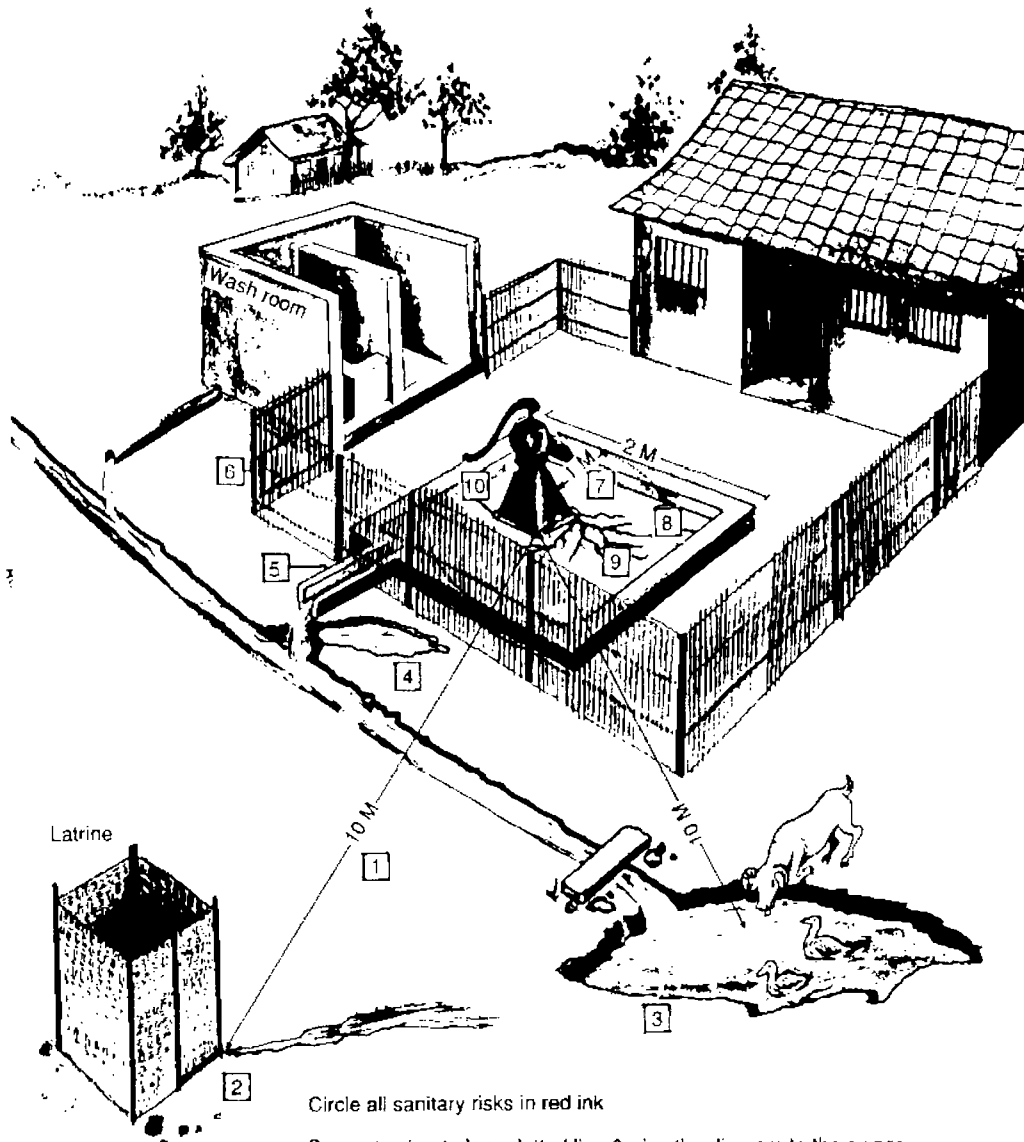

Circle all sanitary risks in red ink

Separate sheet along dotted line & give the diagram to the owner _____
of the facility

Shallow and deep handpumped tubewells

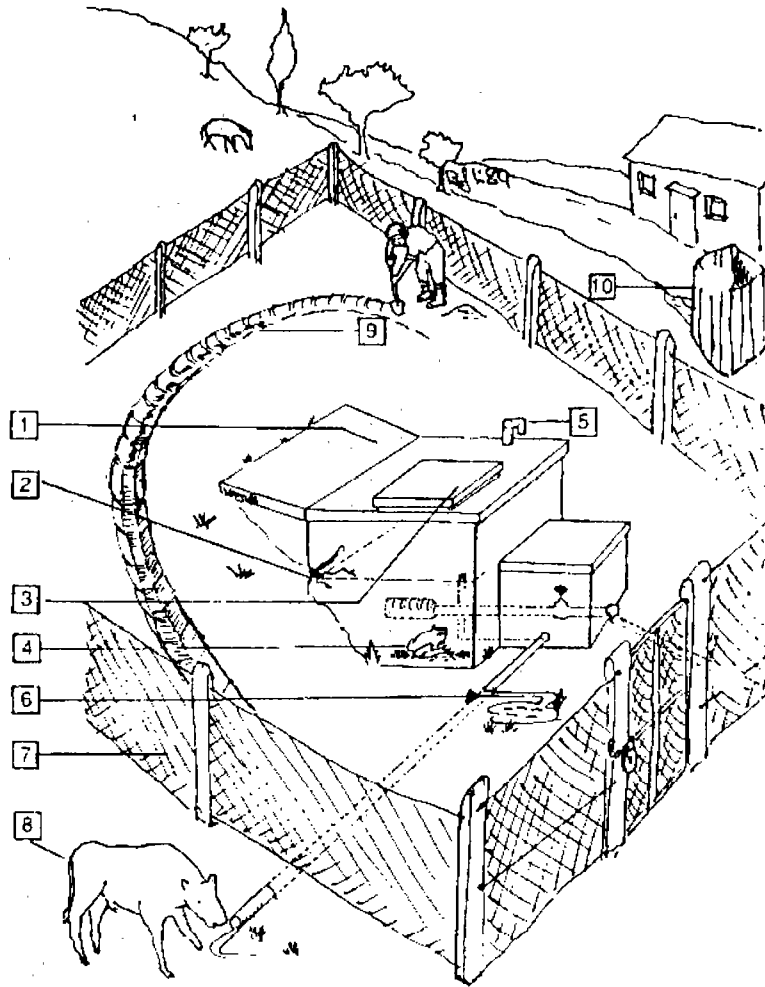

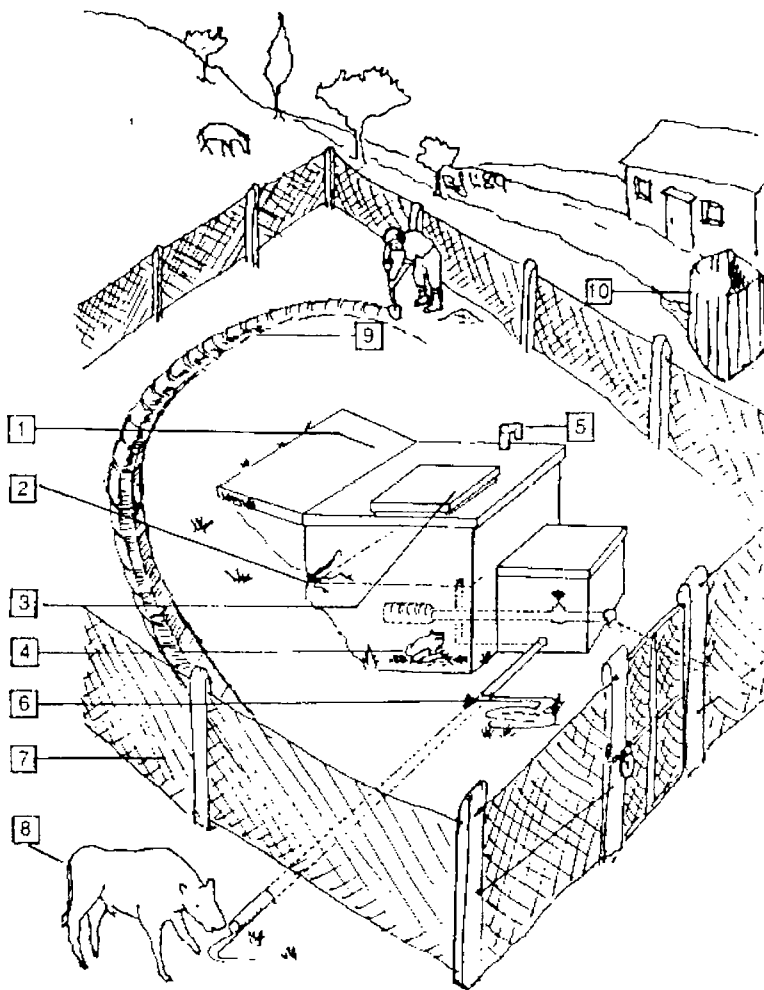

Fact Sheet 2.1

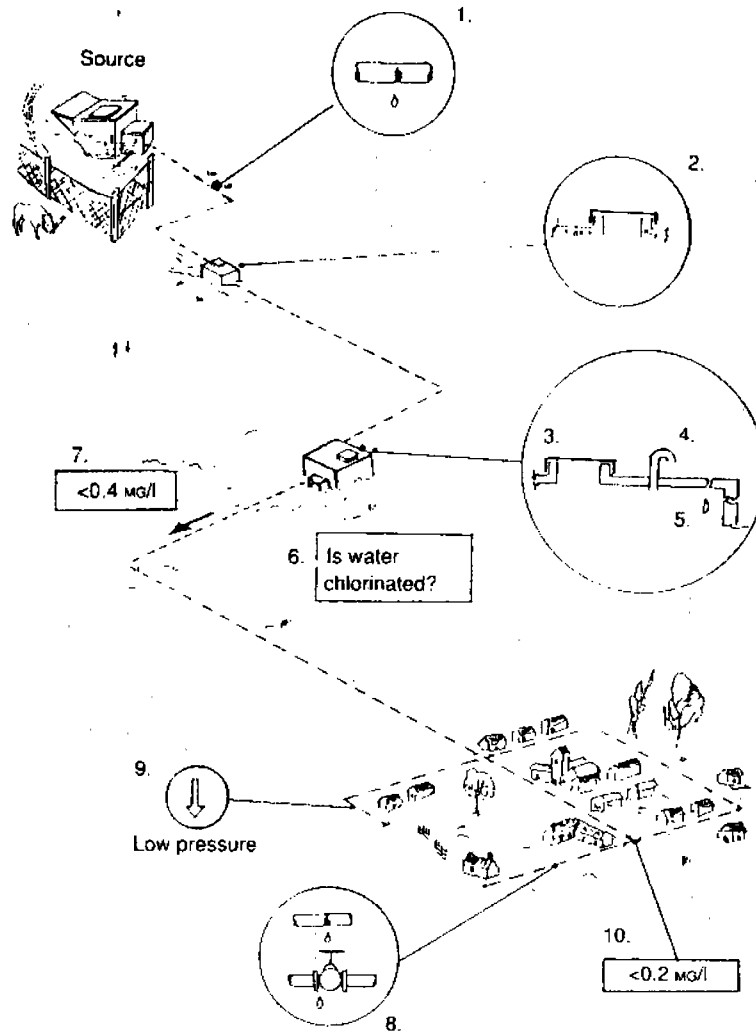

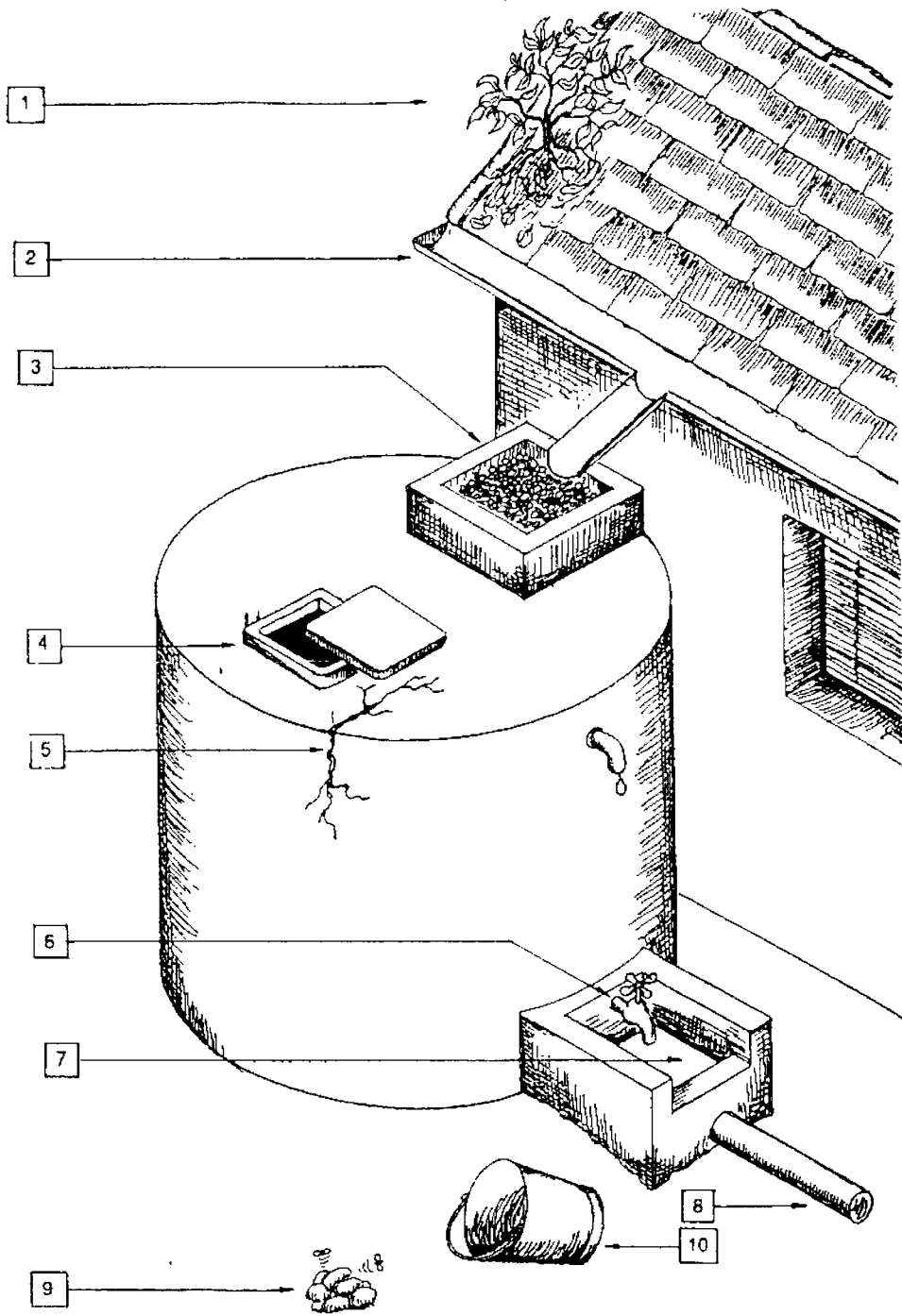

Rainwater catchment tank sanitary survey