

Cleaning and disinfecting wells in emergencies

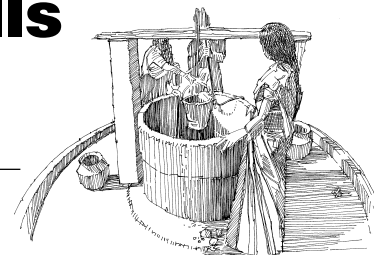

World Health Organization

Steps of cleaning and disinfection

Figure 1 outlines a five stage approach to cleaning and disinfecting wells after natural disasters. It is an emergency approach designed to rehabilitate wells so that they produce water of a similar quality to that supplied before the disaster.

Step 1: Inventory of existing wells

The disaster may have contaminated or damaged a large number of wells. The first step must be to select which wells should be repaired first. The following actions should help you to make your selection.

- Meet with community leaders and ask them to briefly outline which wells serve which sections of the community.
- Select the wells that are most commonly used for drinking water.
- Assess the type and extent of damage to the top of the well.
- Estimate the amount of silt and debris in the well.
- Test the pump to see if it is still working or determine what repairs are necessary.
- Estimate resources needed for repairs (personnel, equipment, time and materials).
- Select the wells that are used most and are easiest to repair first.

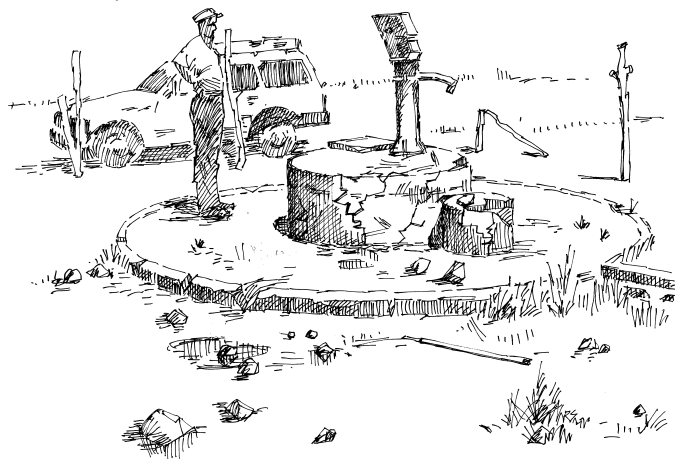

Damaged well head and surround

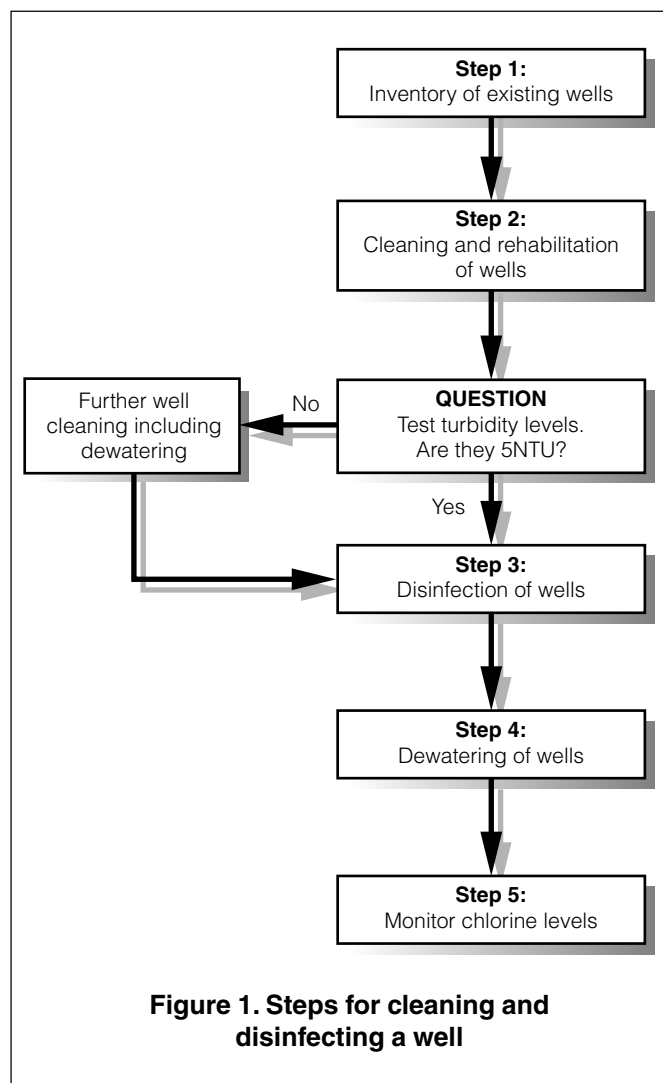

Figure 1. Steps for cleaning and disinfecting a well

Step 2: Rehabilitation and cleaning of wells

Disinfecting a well without first removing the source of contamination provides only temporary health protection. Rehabilitation may include:

1. Repair/replacement of the pumping mechanism.
2. Removal of polluted water and debris from well using either buckets or pumps.
3. Sealing the top of the well using a clay sanitary seal built around top of well (Figure 2).

Cleaning and disinfecting wells

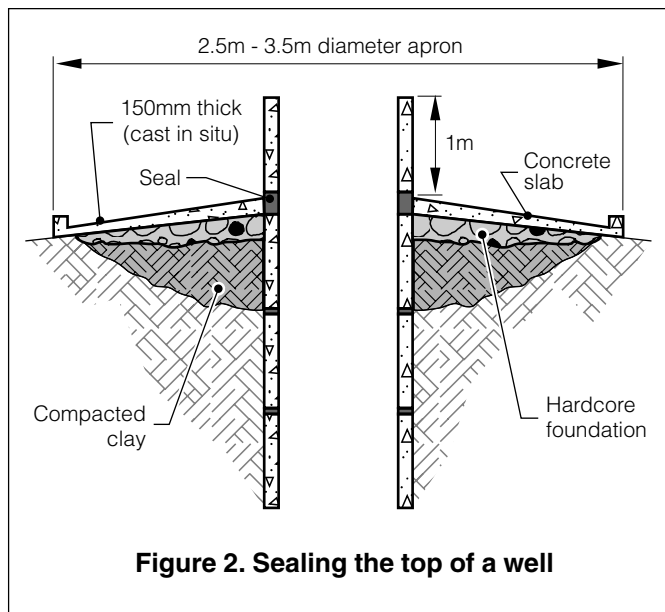

Check turbidity and pH

Following cleaning and repair, allow the water level in the well to return to its normal position. Measure the turbidity and pH levels to check if chlorination will be effective. This can be done using simple hand held equipments similar to that shown in Figure 3. Never chlorinate turbid water because the suspended particles can protect the micro-organisms. Table 1 outlines why pH and turbidity are important and what can be done to ensure guideline levels are met.

If the turbidity of the well water is greater than 5NTU after the cleaning and rehabilitation stage, remove all water in the well once again and scrub the well lining with a strong concentration of bleach in water. Allow the well to refill with water and test turbidity levels again to ensure compliance.

4. Construction of a drainage apron and head wall around the well to prevent surface water, insects and rodents entering the well.
5. Relining the well to reduce subsurface contamination.



Taking a water sample from a well



Examining the turbidity of water

Bleach gives off chlorine gas which is very dangerous. Try to clean the well lining from outside the well using a long handled brush.

If you must enter the well either wear full protective clothing and breathing apparatus and provide a strong air flow inside the well to carry away the chlorine gas.

Cleaning and disinfecting wells

The level of residual chlorine in mg of chlorine per litre of water (mg/l) is determined by dissolving a chlorine testing tablet in the water supply under test, in chamber (A). Compare the colour produced with the standard colours on the wall of chamber (B).

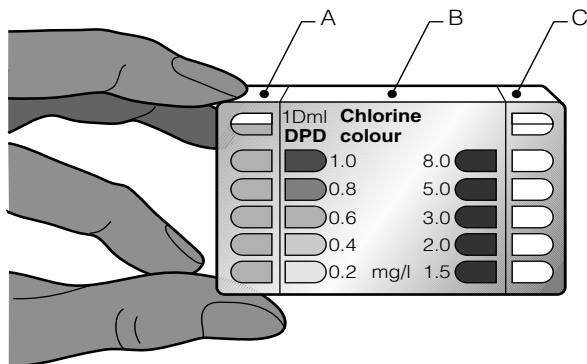

Note: A third chamber (C) would be used if a higher chlorine residual is to be measured.

A separate fact sheet is available on chlorine testing.

Figure 3. A comparator



Testing chlorine levels using a comparator



Testing pH level of water

Step 3: Disinfection of the well

WHO endorses the disinfection of drinking water in emergency situations. There are various ways of doing this but the most common is chlorination as it leaves a residual disinfectant in the water after chlorination.

Chlorine has the advantage of being widely available, simple to measure and use and dissolves easily in water. Its disadvantages are that it is a *hazardous substance* (handled with care) and is *not* effective against all pathogens (e.g. cysts and viruses, which require higher chlorine concentrations).

The chlorine compound most commonly used is calcium hypochlorite as high test hypochlorite (HTH) in powder or granule form. Also used is sodium hypochlorite in liquid bleach or bleaching powder form. Each chlorine compound has a different amount of usable chlorine depending on the quantity of time the product has been stored or exposed to the atmosphere and the way it is made.

Table 1. Physico-chemical parameters

Parameter	WHO GDWQ	Why?	Corrective action
pH	6 – 8	pH of 6.8-7.2 is required to reduce level of chlorine required.	If pH is less than 6 add hydrated lime (calcium hydroxide)
Turbidity	< 5NTU (20NTU emergency limit)	High turbidity (>5NTU) requires more chlorine to oxidise organic matter	Dewater well and rebleach well lining using chlorine solution

Cleaning and disinfecting wells

The best type of chlorine in an emergency is HTH as this normally contains 50 to 70% chlorine.

Box 1 outline methods for calculating appropriate chlorine doses for HTH granule chlorine.

The amount of chlorine needed will depend on the volume of water in the well. Add 1 litre of 0.2% chlorine solutions for every 100 litres of water in the well. Stir the water in the well thoroughly with a long pole and then allow the water to stand for at least 30 minutes.

Step 4: Dewater the well

Following the contact period, remove all water in the well using a pump or bucket. When the well has refilled, wait a further 30 minutes and measure the chlorine concentration using a comparator. If the residual chlorine concentration is less than 0.5mg/l the well is safe to use. If the concentration is greater than 0.5mg/l, remove all the water from the well again and repeat the process.

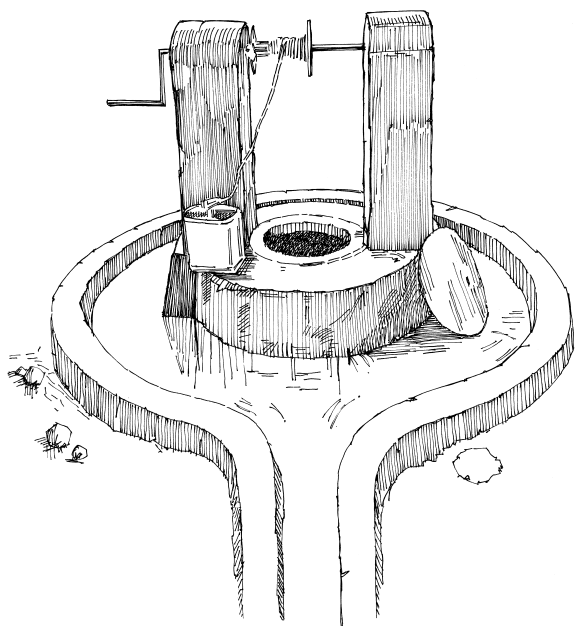

A reconditioned well with windlass and bucket

Box 1. Calculating the chlorine dosage for disinfecting a well using Calcium Hypochlorite (HTH)

Equipment

- 20 litre bucket
- HTH chlorine granules or powder

Method

- Calculate the volume of water in the well using the formula:

$$V = \frac{\pi D^2 \times h}{4}$$

Where

- V = volume of water in the well (m³)
- D = diameter of the well (m)
- h = depth of water (m)
- π = 3.142

- Fill the bucket with clear water from the well.
- Add 50g of HTH and stir until dissolved.

For every cubic metre (m³) of water in the well add 10 litres (half bucket) of the chlorine solution.

Do not allow anyone to use the well during the cleaning process. The water will have a strong concentration of chlorine that will give it a bad taste and smell and could be dangerous.

Further information

Godfrey, S. (2003), 'Appropriate chlorination techniques for wells in Angola', *Waterlines*, Vol. 21, No. 5 pp 6-8, ITDG Publishing, UK.

Wisner, B. and Adams, J. (2002), *Environmental Health in Emergencies and Disasters: A practical guide*, WHO, Geneva.

World Health Organization

WHO Headquarters
Avenue Appia 20
1211 Geneva 27
Switzerland

Telephone: (+ 41 22) 791 21 11
Facsimile: (+ 41 22) 791 3111
Telex: 415 416
Telegraph: UNISANTE GENEVA



This information has been prepared by WEDC

Author: Sam Godfrey Series Editor: Bob Reed Design: Glenda McMahon Illustrations: Rod Shaw Graphics: Ken Chatterton
Water, Engineering and Development Centre, Loughborough University, Leicestershire, UK.
Phone: +44 1509 222885 Fax: +44 1509 211079 E-mail: WEDC@lboro.ac.uk Website: www.lboro.ac.uk/wedc