

Composting latrines

Composting latrines are shallow vaults, into which kitchen waste and similar materials are added as well as excreta. The waste and excreta break down together to produce a compost which can be dug out and used as fertilizer.

In a composting latrine there are two shallow vaults, only one of which is used at a time. When one is nearly full, it is covered with soil and left for at least two years for the excreta and waste to decompose and for the pathogenic (disease-causing) germs in it to die. While the first vault is closed, the second is used. When the second is nearly full, the first is opened, the compost dug out for use as fertilizer and the first vault re-used.

The vaults must not receive water or become flooded and so they are usually built partially above ground level. Organic waste should be added daily to help the excreta break down. Ash, powdered horse dung, sawdust or similar material should be added after each use. This helps to minimize odours.

The advantages of a composting latrine are that it does not need to be moved and new vaults do not have to be dug. The compost produced is a good fertilizer and soil conditioner, and the latrine also disposes of kitchen waste. Composting latrines are, however, more expensive and more difficult to build than pour flush or VIP latrines. As with all latrines, if they are not used properly then there is a risk of transmission of diseases.

Composting latrines are most appropriate where there is a demand for the compost produced as a fertilizer and soil conditioner. It is essential that any programme supporting construction of composting latrines include a substantial educational component to ensure their proper management and that fresh excreta are not handled and used. A typical composting latrine is shown in Figure 1.

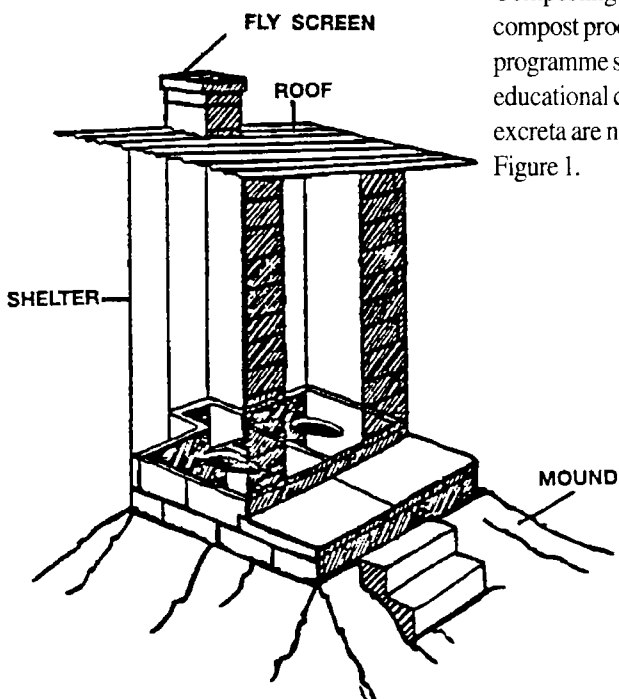

Figure 1. Composting latrine

Where to build a latrine

When planning to build a latrine, a site should be chosen which is :

- Downhill and the minimum safe distance from the nearest drinking water source. This will be site specific and should be established for each water source based on the local hydrological and hydrogeological conditions. A distance of 30 metres has been suggested by some workers as standard practice. It is recommended that this figure is taken as a guide to establishing a minimum safe distance, in the absence of local information.
- Near to and down-wind from the house, with the entrance facing the house.
- On slightly-raised ground, so that rainwater can drain away easily.

Figure 2 shows where to locate a composting latrine.

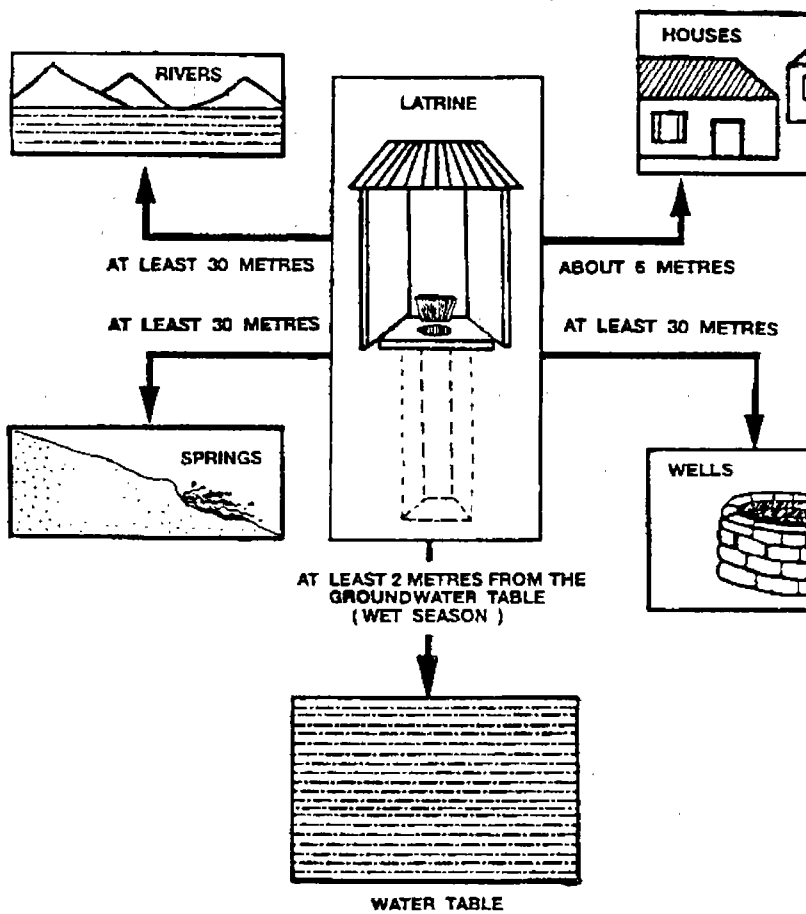

Figure 2. Where to build a latrine

The vaults

It is very important that the composting latrine vaults are always kept dry. Any water getting into the composting excreta will spoil the compost and cause problems of odour.

If the groundwater level is very close to the surface, the vaults can be made almost completely above ground and can be sealed with cement plaster to stop water seeping in. An example of how to build the vaults is detailed below and should be adapted to local circumstances and materials.

- Dig a hole 2.0 metres by 2.4 metres and 0.5 metres deep, with space for the vent pipe (see Figure 3). If water appears in the pit, then it can be made less deep.

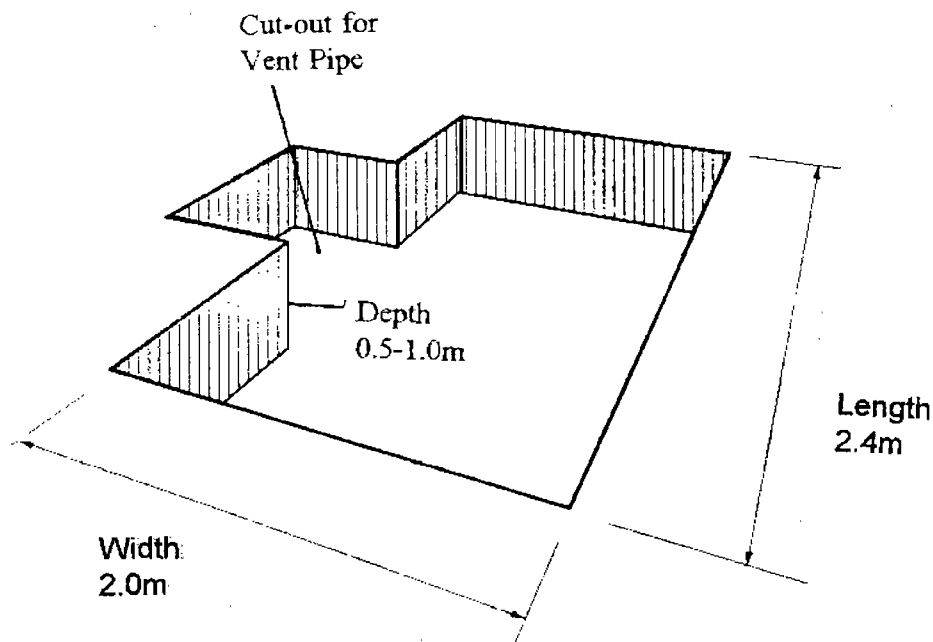

Figure 3. Pit for a composting latrine

- If the ground is very wet, build the vaults on a mound to keep them above water. In this case, the latrine vault needs a cement base to keep it waterproof.
- Position a timber framework for the base. The framework should be 1.5 metres by 1.8 metres. The concrete needs to be 50 millimetres to 70 millimetres thick. Mix the concrete : one shovelful of cement, two shovelfuls of sand and four shovelfuls of gravel. Pour the concrete into the framework until it is about 50 millimetres deep (see Figure 4). Cover the concrete with used cement bags or grass and keep damp for 5 days until the concrete is fully hardened. If the groundwater level is well below the bottom of the vaults, there is no need for a concrete floor.

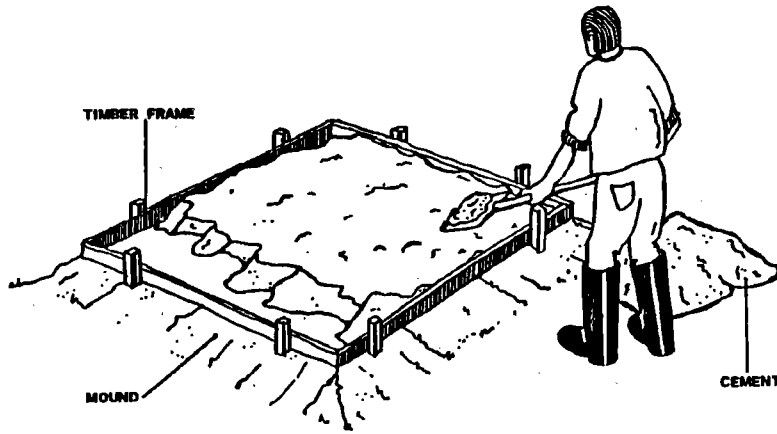

Figure 4. Cement floor for raised vaults

- Build the walls of fired bricks or cement blocks and cement mortar up to 0.8 metres high. Build a dividing wall for the two vaults and the base for the vent pipe, which should be at least 250 millimetres square to allow good air flow (see Figure 5).

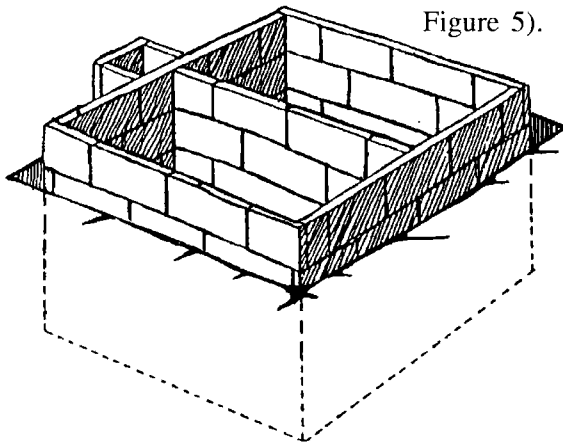

Figure 5. Composting latrine vaults

- Build a concrete support beam 0.8 metres from the back of the vaults across the dividing wall. Support the beam with timber while the cement hardens well. Add another layer of blocks or two layers of bricks to the walls of the vaults (see Figure 6).

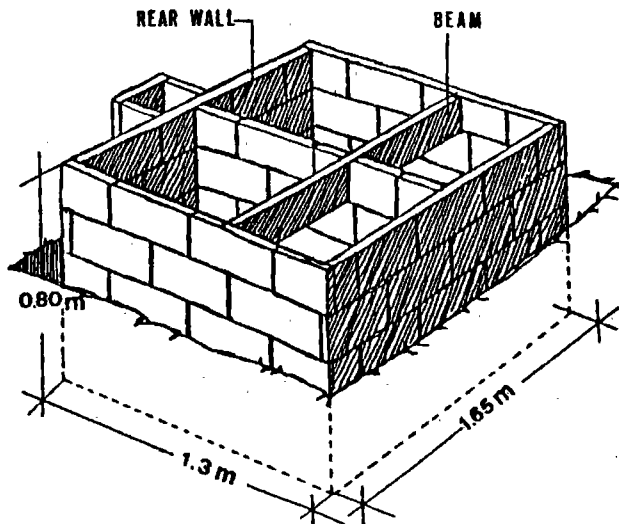

Figure 6. Support beam

- Lay flat bricks or blocks around the front part of the two vaults to form a ledge to support the vault covers which give access to allow for the removal of the compost. Then build a final layer of blocks or two layers of bricks around the rear part of the vaults and the vent pipe. Leave a gap between the vent pipe and the vaults, to allow odours to pass up the vent pipe (see Figure 7).

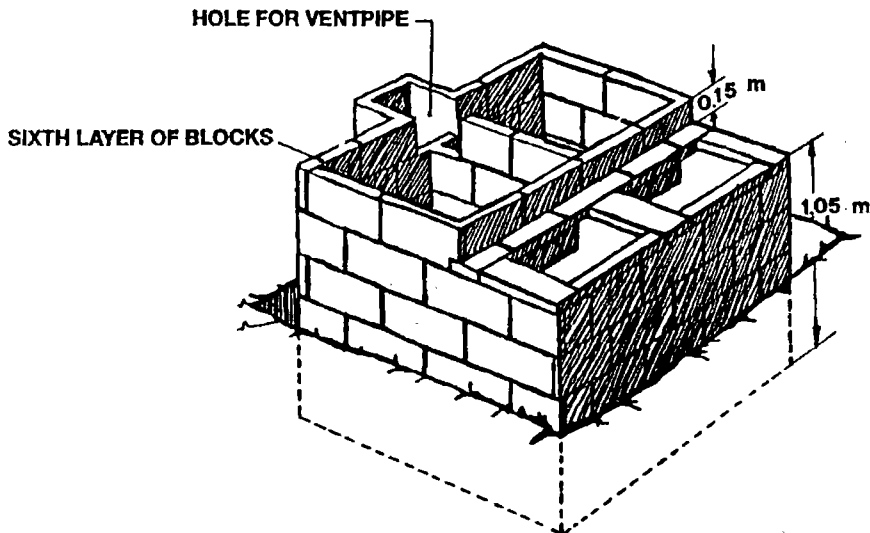

Figure 7. Cover supports

Note that the total depth of the vaults is about 1.05 metres below the vault covers and 1.2 metres below the latrine slabs (see Figure 8).

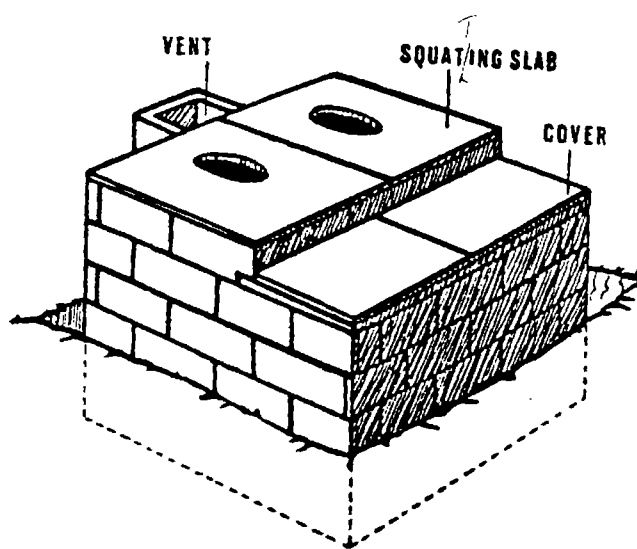

Figure 8. Finished vaults

The squatting slabs support the user and cover the pit. The slabs should be big enough to cover the vaults without leaving any spaces for flies or vermin to get in. Two squatting slabs are needed to cover the vaults and two covers are required to allow for the removal of compost.

Both the squatting slabs and the covers are made from reinforced cement concrete.

Instructions for making a simple squatting slab are presented below.

To construct a simple reinforced concrete covering slab :

- Dig a square, shallow pit, about 200 millimetres wider and longer than the pit and 50 millimetres deep. Be sure that the bottom of the pit is level and smooth (see Figure 9).

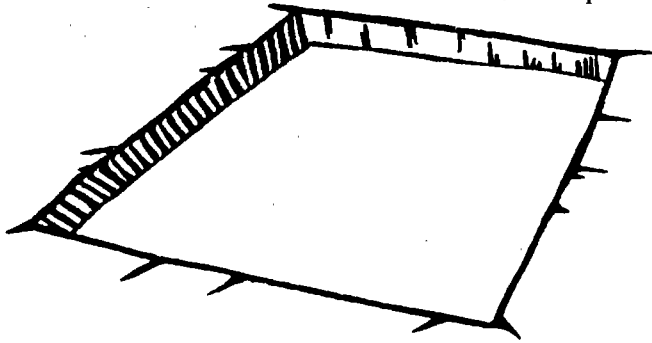

Figure 9. Preparing a pit for cover slab casting

- Make or cut a wire mesh or grid to lie inside the pit. The wires can be 6 to 9 millimetres thick and about 200 millimetres apart (see Figure 10). Cut a hole about 250 millimetres in diameter in the middle of the grid.

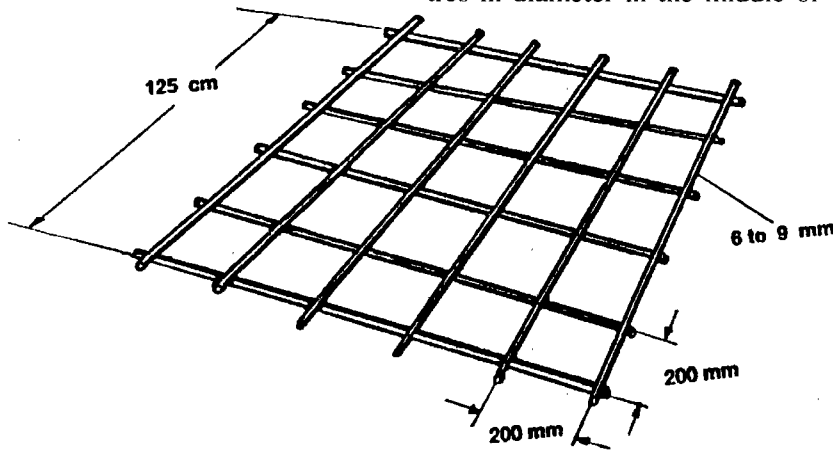

Figure 10. Reinforcement grid

- Put the grid in the pit. Bend the ends of the wires, or put a small stone at each corner, so that the grid stands about 20-30 millimetres off the bottom of the pit (see Figure 11).

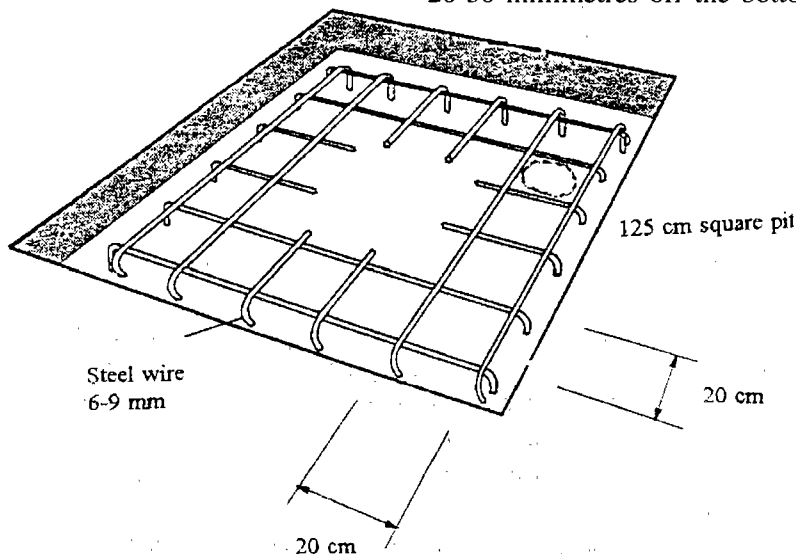

Figure 11. Laying the grid in the pit

- Put an old bucket with a bottom about 200 millimetres across or a template in the shape of a keyhole in the hole in the grid (see Figure 12).

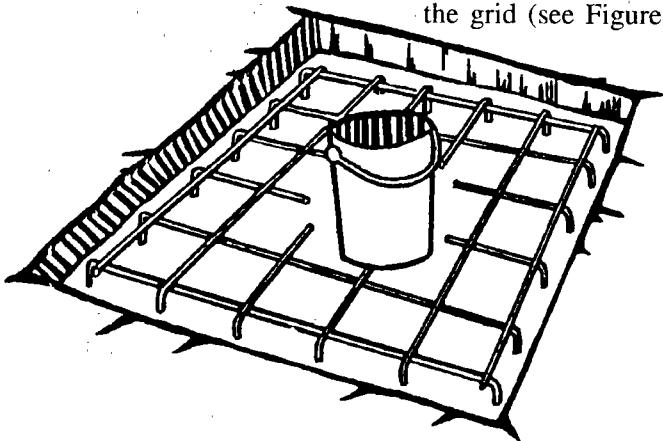

Figure 12. Making a squat hole

- Mix cement with sand, gravel and water (with each shovel of cement, mix 2 shovels of sand and 4 shovels of gravel). Mix well and pour it into the pit until it is about 50 millimetres thick (see Figure 13).

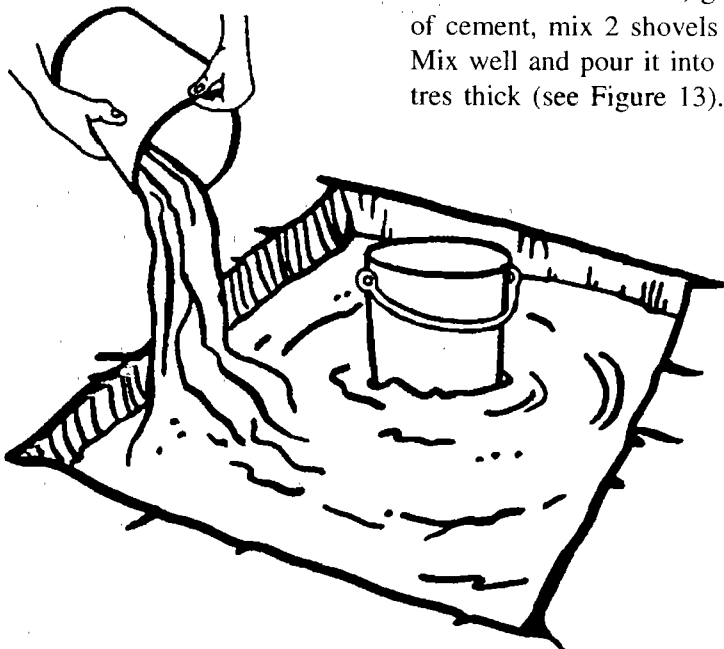

Figure 13. Laying the slab

- Remove the bucket when the cement is beginning to harden (after about three hours). Then cover the cement with damp cloths, cement bags, sand, hay or a sheet of plastic and keep it damp. It is important that the cement is kept damp for five days to reach its full strength. Remove the slab after five days.

The mound

The function of the mound is to protect the pit and base from surface water which otherwise might enter and prevent the composting process, as well as damaging the pit. The mound should be built up to the level of the floor and be well tamped. It should extend at least 0.5 metres beyond the base on all sides. In exceptional cases, the mound may be built up considerably above the ground for protection against tides and flood waters.

The mound will normally be built with the earth excavated from the pit or surrounding area, and may be consolidated with a stone facing to prevent it from being washed away by heavy rains. In front of the entrance door, it is a good idea to supplement the mound with a masonry or brick-built step which makes the mound resistant to use.

The shelter

The shelter is for privacy and protects the user and the latrine from the weather. The shelter can be made from any suitable materials and is placed on the base of the latrine. The shelter should be high enough for comfort, although the height will depend on the users of the latrine. Openings of 100 to 150 millimetres width should be provided at the top of the shelter walls for constant ventilation.

The roof should cover the shelter completely and have a large overhang to protect the mound and the walls from rain or roof drainage.

Use and daily maintenance

Before using the compost latrine for the first time, put a large amount of leaves, grass, weeds, sawdust, horse and cow dung into the vault which is to be used. This will help to absorb odours and liquid.

To make the compost latrine work, organic waste, such as grass clippings, leaves, sawdust, and fruit and vegetable peelings, must be put into the latrine every day or at least once a week. These help the excreta to break down more quickly, stop odours and also make better compost. After each use, material such as ash, powdered horse or cow dung or sawdust should be thrown into the latrine to absorb odours. A sack of this material with a scoop should be left in the compost latrine shelter ready for use after defecation.

Once the vault in use is nearly full (about 0.5 metres below the squatting plate), the vault should be sealed and the second vault opened. The full vault should be left closed for at least two years to allow the compost to form. A cover should be placed over the hole in the slab of the vault not in use to prevent people using it.

Any grass or plants growing around the latrine should be kept well cut. Do not put cans, glass or plastic bottles into the compost latrine. These will not break down and will fill the compost latrine up more quickly. The cover slab and squat hole should be cleaned daily, for example with ashes.

During an epidemic, the floor and lid of the latrine should be cleaned daily with a disinfectant such as bleach (sodium hypochlorite).

Use of excreta as fertilizer

After at least two years, the excreta can be dug out of the first pit and used as fertilizer. Fresh excreta contain many germs, but these die if the excreta are left in the pit for two years or more. Provided that no water is allowed to get into the pit, the excreta also become dry and odourless. To allow the composted excreta to break down completely in the soil, the compost should be buried in trenches and covered over with soil.

Care of the latrine

A composting latrine can be pleasant to use and help to prevent the spread of infectious diarrhoeal diseases such as cholera, but only if it is kept clean. Clean the latrine floor daily with a brush (which should be kept in the latrine and used only for this purpose) and ashes, corn husks or similar materials.